

Want To Give Your Store The Edge?

It's easy with our POP Floor Displays & Accessories



W A L L S + F O R M S | RETAIL DISPLAY SOLUTIONS

Ready-to-Ship Floor Displays

Floor modules are built to last. To lower freight costs and damage, all floor displays are shipped “knock down”. Each Unit has been designed for quick and easy assembly. Panels, connectors and bases are manufactured with state-of-the-art equipment and provide a consistent secure fit, even with repeated assembly and disassembly. Whether it is one display or a national “roll-out”, quality and service are guaranteed.

Benefits:

- **In-Stock and Ready-to-Ship**
- **Packaged to Ship via UPS/Fed-Ex[†]**
- **No Minimums on Stocked Colors**
- **Easy to Assemble**
- **Competively Priced**

Call us today to learn more!

Triangle Display*

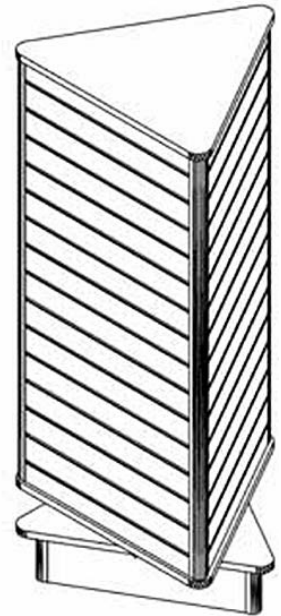
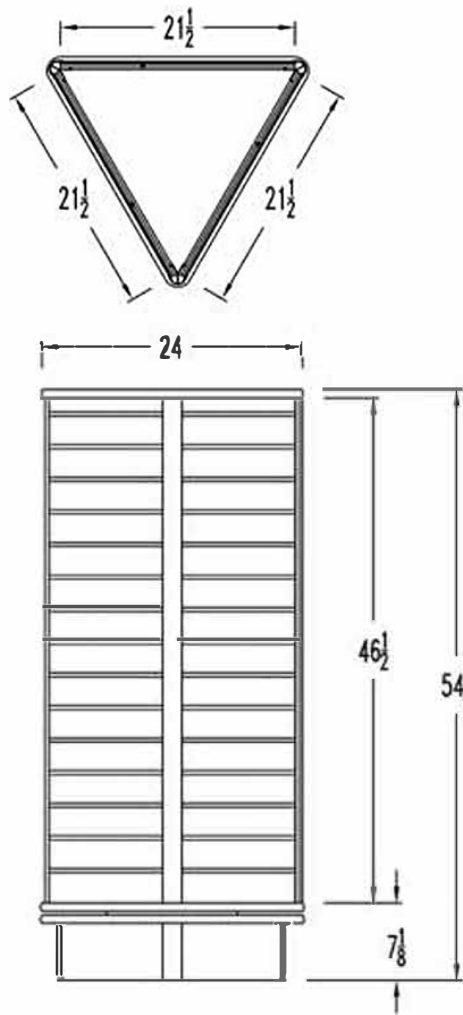
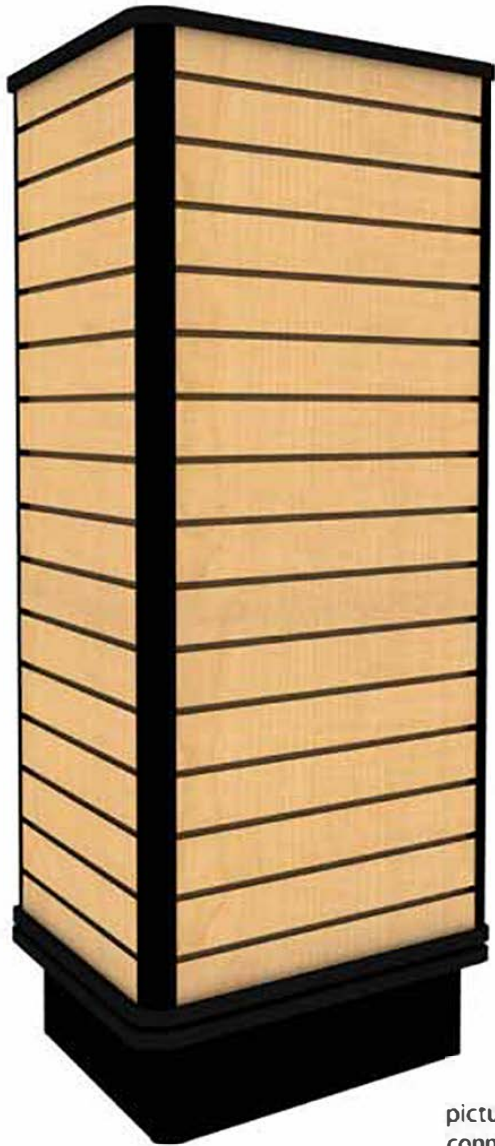

*optional, fixed or rotating base is available for this unit

pictured here is a custom combination of maple panels, black connectors, black groove strips and black rotating base

Item #	Description	Unit Dim.	Shipping Dim.	Weight
6000	Triangle Unit	47.25"x24"x21.125"	56"x18"x4"	70 lbs.
6012	Triangle Rot. Base	6"x24"x21.125"	28"x28"x11"	45 lbs.
6010	Triangle fixed base	6"x24"x24"	28"x28"x11"	16 lbs.

Displays stocked in the following colors:

No minimums required on stocked colors**

**Please call to discuss additional color options. (minimum quantities may apply)



White



Almond



Gray



Maple

Call us today to learn more!

Cube Display*

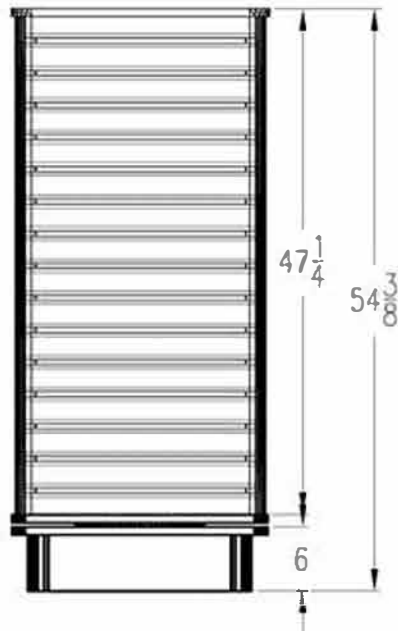
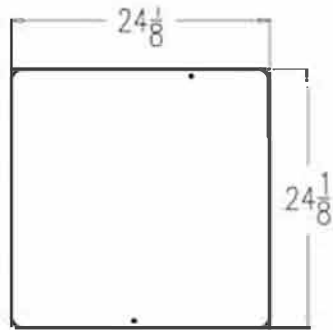

*optional, fixed or rotating base is available for this unit

pictured here is a standard combination of white panels, white connectors, white groove inserts and white rotating base

Item #	Description	Unit Dim.	Shipping Dim.	Weight
6002	Cube Unit w/o base	47.25"x24"x24"	49"x27"x3"	50 lbs.
6013	Square Rot. Base	6"x24"x24"	28"x28"x11"	56 lbs.
6011	Square fixed base	6"x24"x24"	28"x28"x11"	42 lbs.

Displays stocked in the following colors:

No minimums required on stocked colors**

**Please call to discuss additional color options. (minimum quantities may apply)



White



Almond



Gray



Maple

Call us today to learn more!

Small Pinwheel Display*

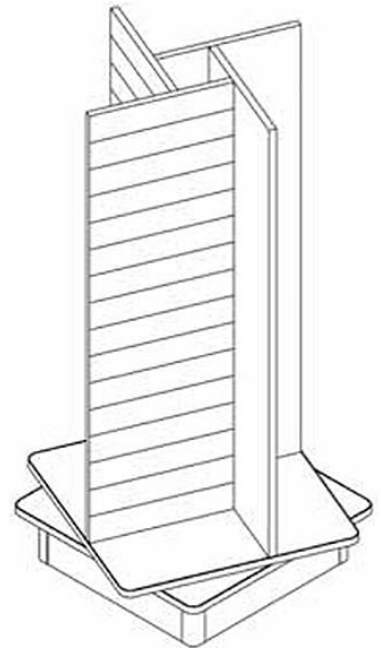
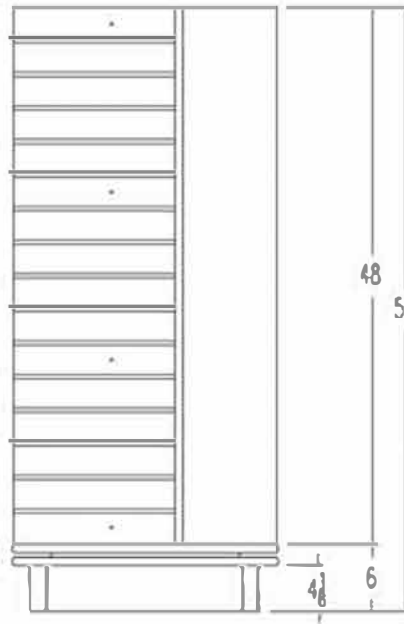
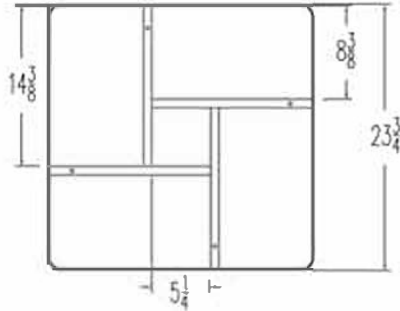

*optional, fixed or rotating base is available for this unit

pictured here is a standard combination of gray panels, gray groove inserts and gray rotating base

Item #	Description	Unit Dim.	Shipping Dim.	Weight
6003	Small Pinwheel w/o base	48"x24"x24"	53"x17"x5"	56 lbs.
6011	Square fixed base	6"x24"x24"	28"x28"x11"	42lbs
6013	Square Rot. Base	6"x24"x24"	28"x28"x11"	56 lbs.

Displays stocked in the following colors:

No minimums required on stocked colors**

**Please call to discuss additional color options.
(minimum quantities may apply)



White



Almond



Gray



Maple

Call us today to learn more!

Large Pinwheel Display†

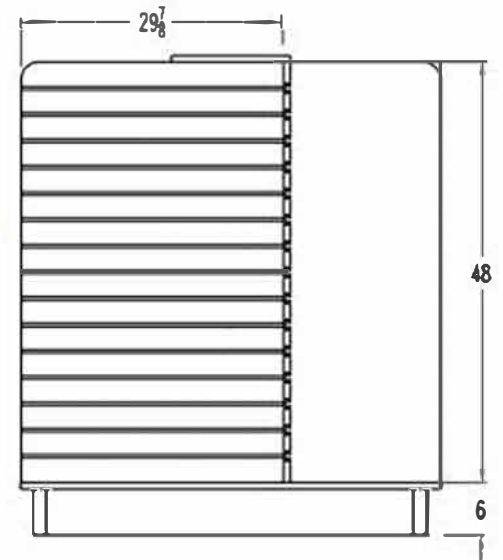
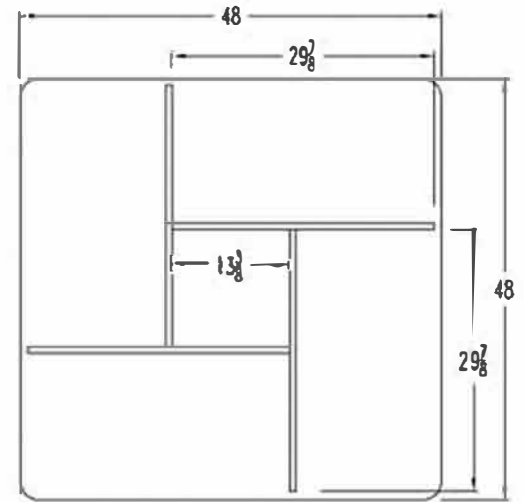
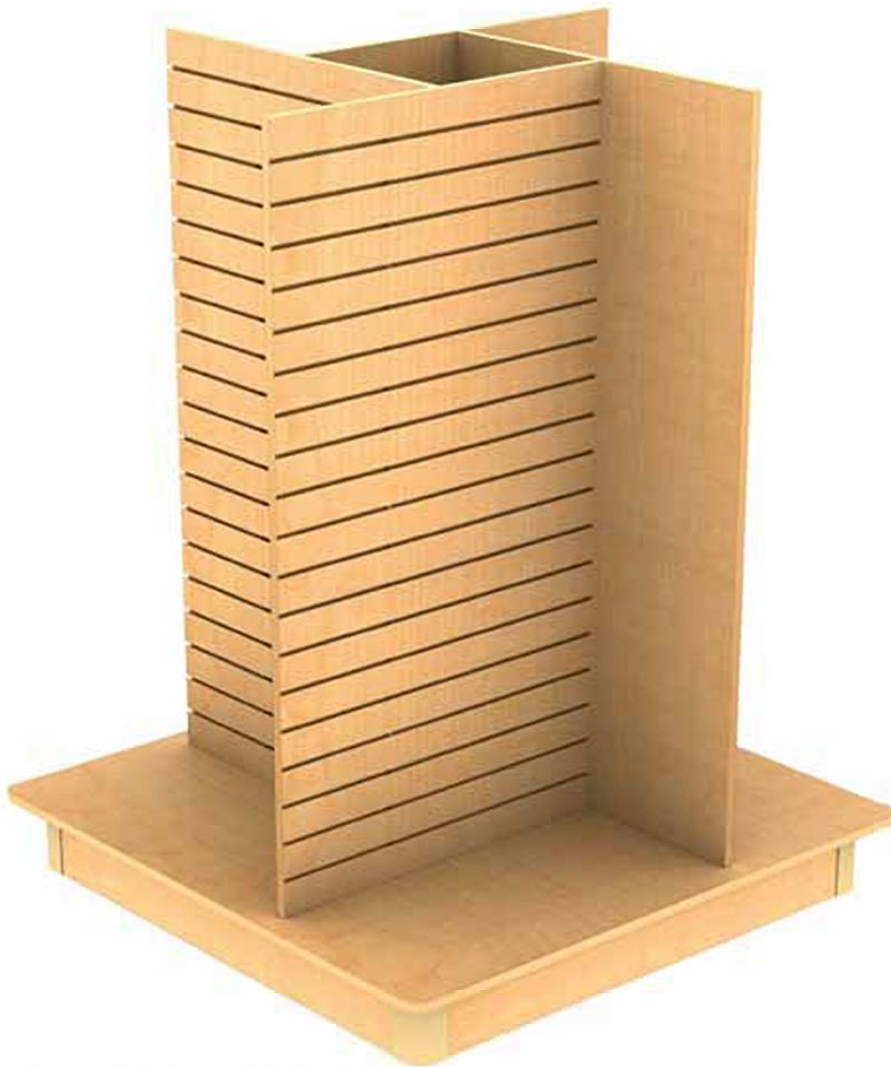

pictured here is a standard combination of maple panels, maple groove inserts and maple base

Item #	Description	Unit Dim.	Shipping Dim.	Weight
6005	Large 48" Pinwheel	54"x48" x48"	16" x 51" x 51"	250 lbs.

† Due to the size & weight of this unit it will ship LTL *does not ship* UPS/Fed-Ex

Displays stocked in the following colors:

No minimums required on stocked colors**

**Please call to discuss additional color options.
(minimum quantities may apply)

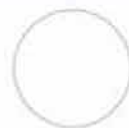

White



Almond



Gray



Maple

Call us today to learn more!

H-Unit Display*

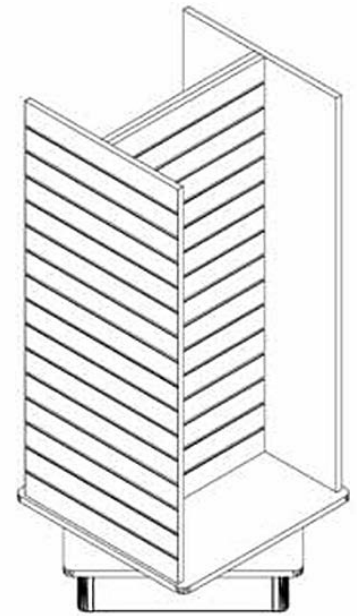
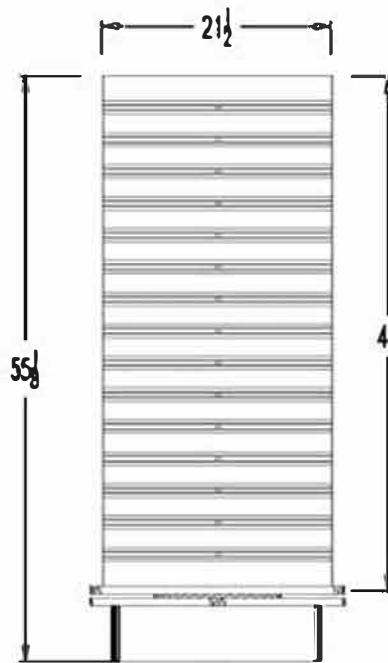
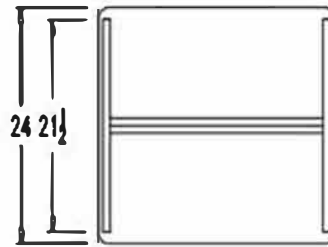

*optional, fixed or rotating base is available for this unit

pictured here is a standard combination of maple panels, almond groove inserts and maple rotating base

Item #	Description	Unit Dim.	Shipping Dim.	Weight
6006	H Unit w/o base	48"x24"x24"	50"x20"x5"	80lbs
6011	Square fixed base	6"x24"x24"	28"x28"x11"	42lbs
6013	Square Rot. Base	6"x24"x24"	28"x28"x11"	56lbs

Displays stocked in the following colors:

No minimums required on stocked colors**

**Please call to discuss additional color options.
(minimum quantities may apply)



White



Almond



Gray



Maple

Call us today to learn more!

H-Gondola Display[†]

W A L L S + F O R M S | RETAIL DISPLAY SOLUTIONS

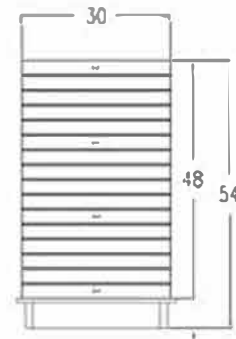
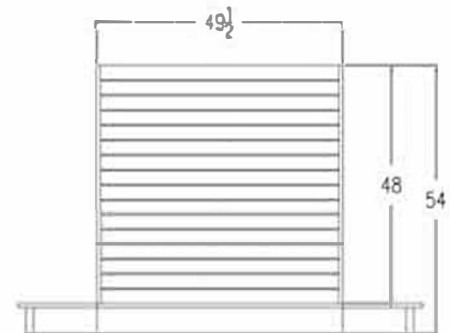
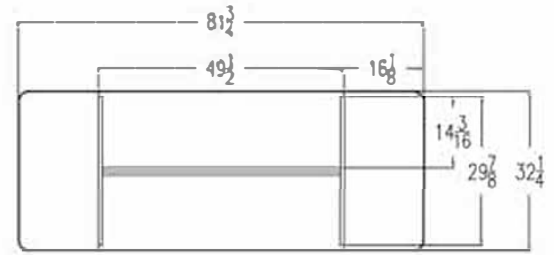
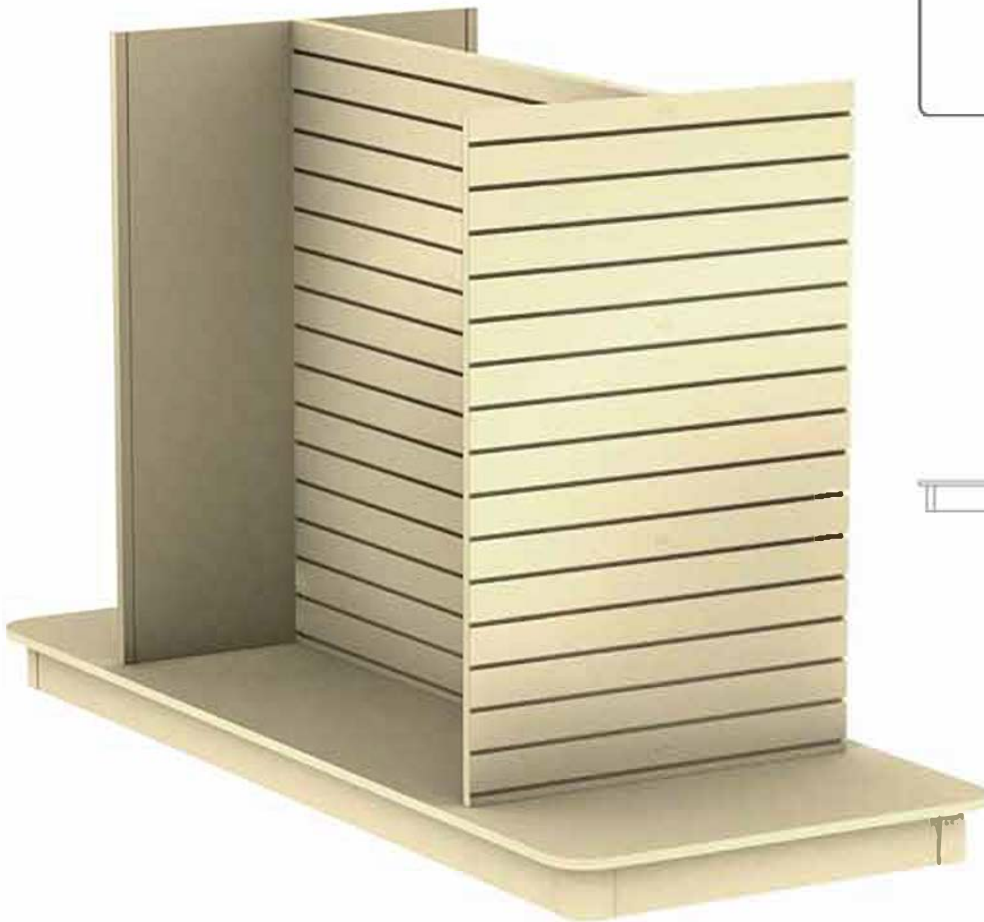

pictured here is a standard combination of almond panels, almond groove inserts and base

Item #	Description	Unit Dim.	Shipping Dim.	Weight
6007	H Gondola Modular	54"x81.5"x32"	16" x 51" x 51"	300 lbs.

[†] Due to the size & weight of this unit it will ship LTL does *not* ship UPS/Fed-Ex

Displays stocked in the following colors:

No minimums required on stocked colors**

**Please call to discuss additional color options.
(minimum quantities may apply)



White



Almond



Gray



Maple

Call us today to learn more!

POP Floor Displays, In Stock and Ready to Ship...



W A L L S + F O R M S | RETAIL DISPLAY SOLUTIONS

Walls+Forms, Inc.
P.O. Box 741112
Dallas, Texas 75374-1112

P. 972.745.0800 | F. 972.304.8402

www.wallsforms.com
info@wallsforms.com